



MODULAR
SERVICES COMPANY

SILHOUETTE™

Installation Manual

SILHOUETTE™



OVERVIEW

The Silhouette™ is a UL-listed, semi-recessed, horizontal medical gas and electrical service assembly which extends only 1.25" from the wall, accommodating tight space constraints and allowing for larger and safer working environments. This system uses up to four horizontal equipment channels and two component tiers to conveniently locate services such as medical gas, electrical and communications (Figure 1). After installation, the Silhouette appears and operates as a single headwall.

Figure 1.

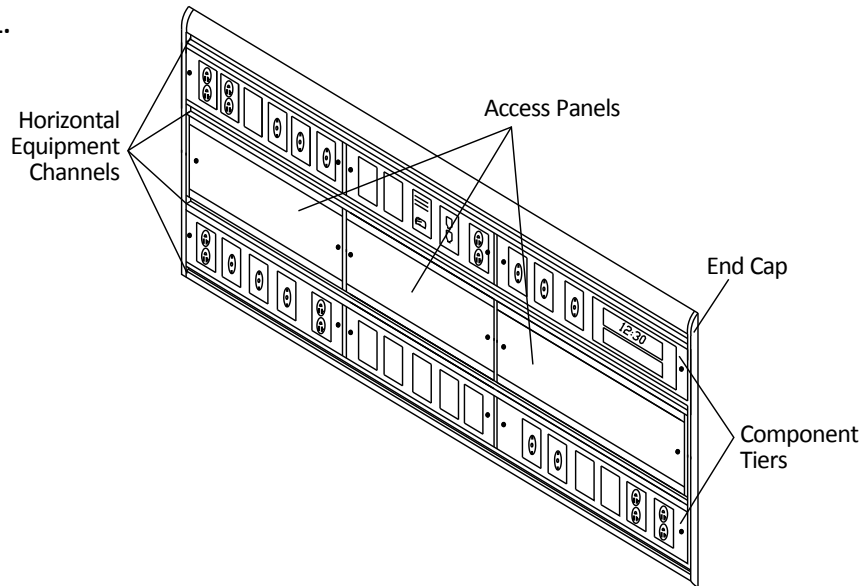

UNPACKING AND INSPECTION

1. Upon receipt of units and prior to unpacking, inspect shipping containers for damage. Document any damage found and notify the carrier and Modular Services Company.
2. Locate the carton for the unit you wish to install. Labels at each end of the carton identify the unit type and general description of contents, as well as the room number or area of installation (if applicable).
3. Unpack unit from shipping containers, taking care not to damage unit.
4. Verify that all components are included, according to the packing slip.
5. Inspect units for defects in materials or workmanship prior to installation. It is the responsibility of the customer to report any damage or deficiencies to Modular Services immediately upon discovery.

UNIT INSTALLATION

The Silhouette is delivered to the job site in three vertical sections, with an integral rough-in designed to reduce installation time. The vertical sections interlock easily and are completely pre-wired with service connections terminating above the accessible ceiling line (or as indicated on the project drawings). See Figure 2.

Vertical frame sections include a precision alignment mechanism that ensures proper position of horizontal channels and tier components. Vertical frame sections can be ganged together to form horizontal tier sections of various lengths and will become an integral part of the building wall. Each section is 90" tall with the exception of the center section, which contains the electrical service connection junction boxes. For the 90" sections, additional framing to the ceiling space above is to be supplied by others, as required. This section extends above the ceiling (accessible ceiling only) for ceilings up to 9'6".

WARNING: For installation of Silhouette units, make certain the walls are constructed of at least 20-gauge steel studs on 16" (41cm) centerlines and covered with a minimum of 5/8" (15.9mm) gypsum wallboard. Failure to do so could compromise the structural integrity of the partition.

Figure 2.

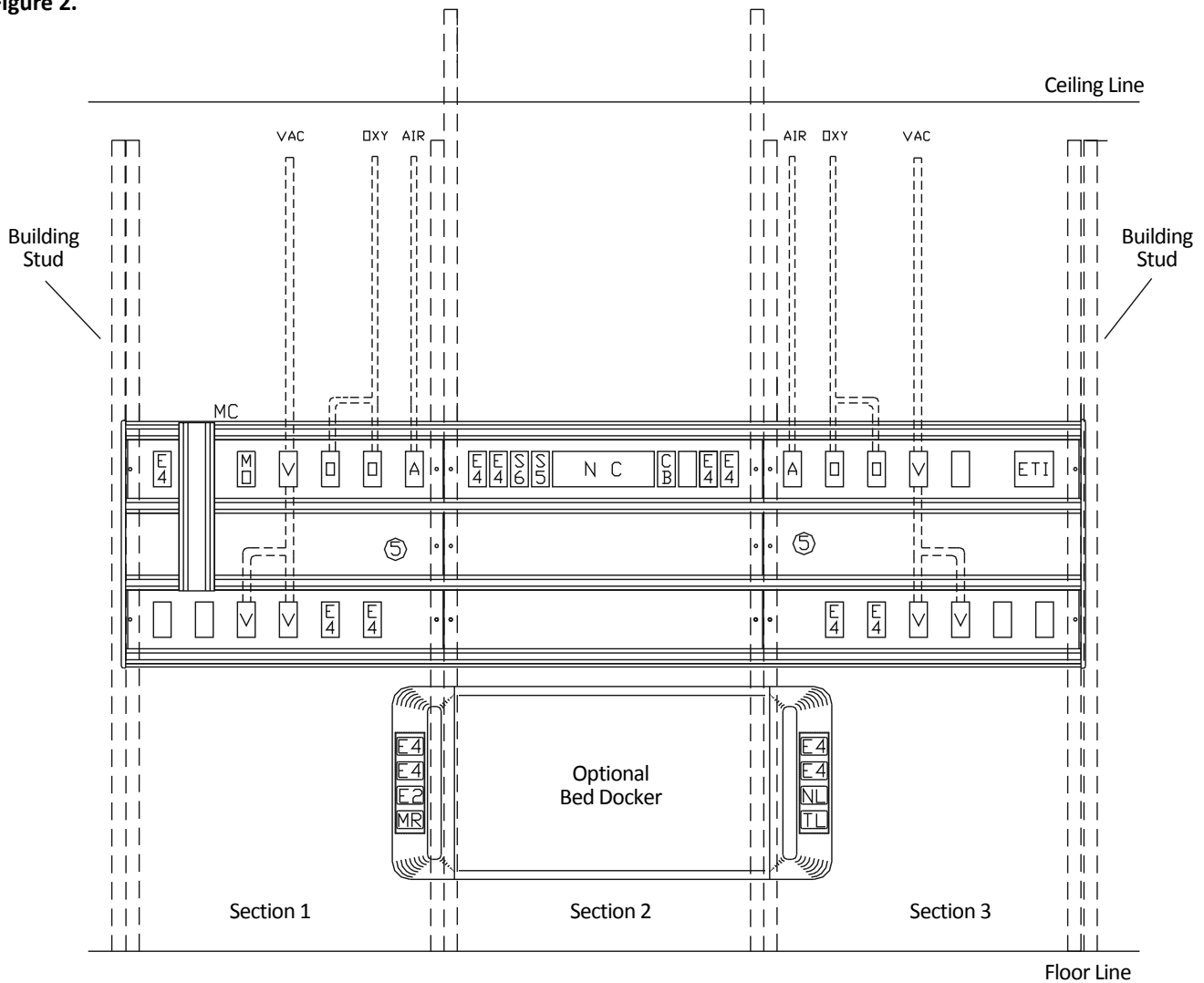

1. Place Section 1 (left section) into bottom track and slide next to existing stud (Figure 3). Be sure stud is plumb and attach nailers to stud with screws. Do not tighten screws until all sections have been placed and leveled.
2. Install Section 2 (center section) in the same manner as Section 1. Slide stud extension into top plate and attach with sheet metal screws (Figure 4).
3. Place Section 3 (right section) into bottom plate and attach to previous section (Figure 5). All sections should be attached to one another and the finger joints of the sections should be tight and flush. Level the completed sections, tighten all screws, and complete attachment to top and bottom plates.
4. Z-brackets are pre-attached to unit to match building stud size and provide attachment points for gypsum board on the back side of unit (Figure 6).

Horizontal channels are continuous length (up to 10') and are field-attached to horizontal tiers and vertical frame sections. Channel fasteners are concealed behind a snap-in vinyl trim. The lower channel surface is flat and smooth to facilitate ease of cleaning. Channels are removable to allow replacement as necessary.

Figure 3.

**Section 1
Rough-in**

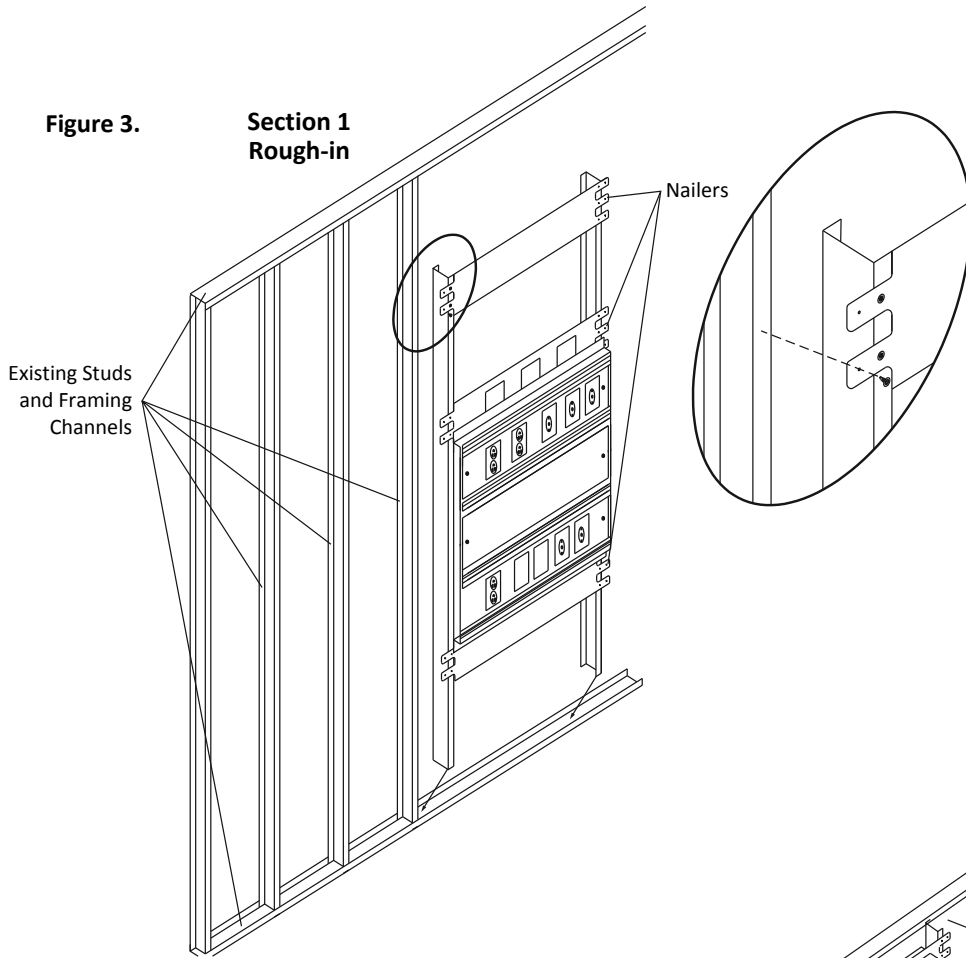

Figure 4.

**Section 2
Rough-in**

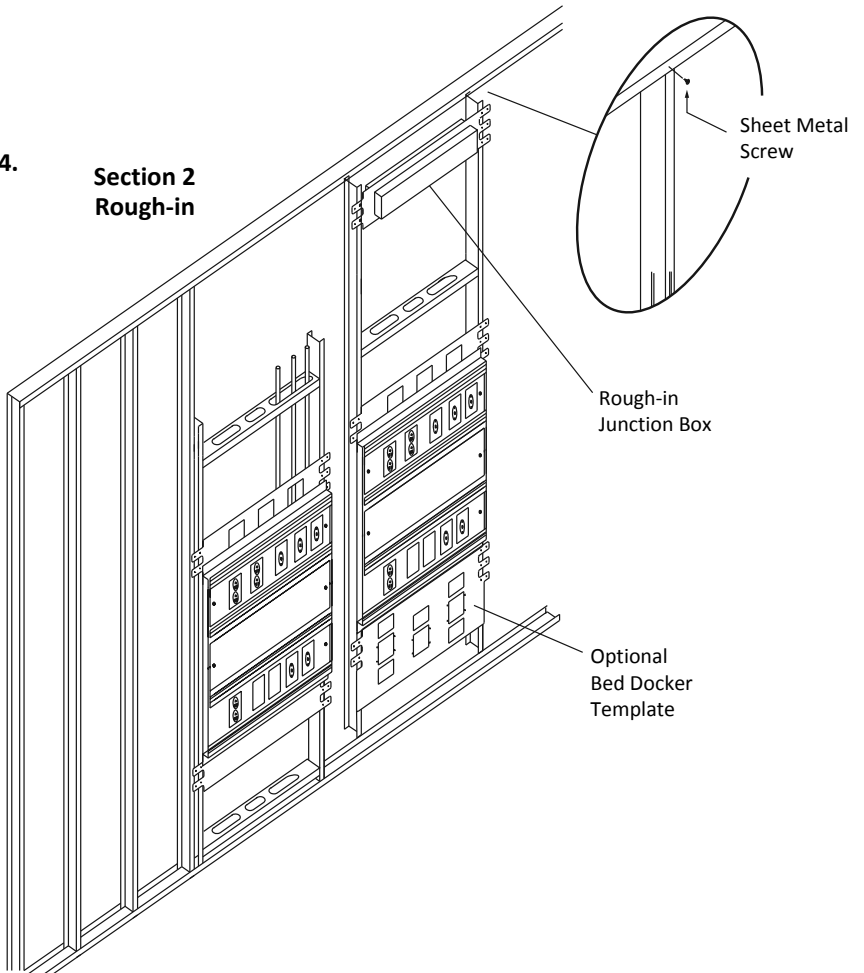

Figure 5.

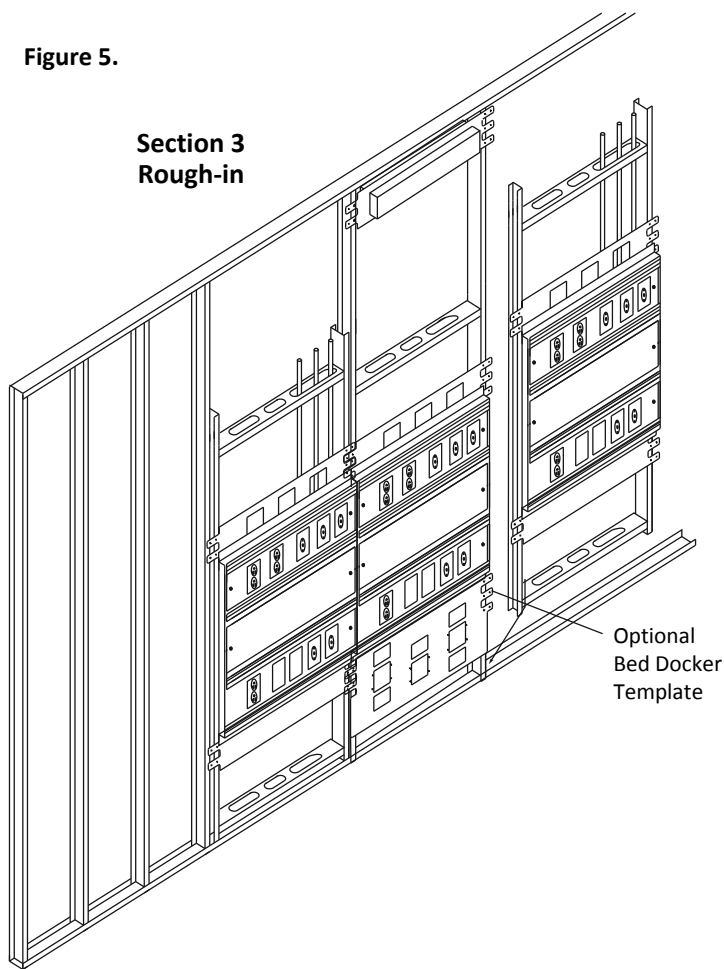
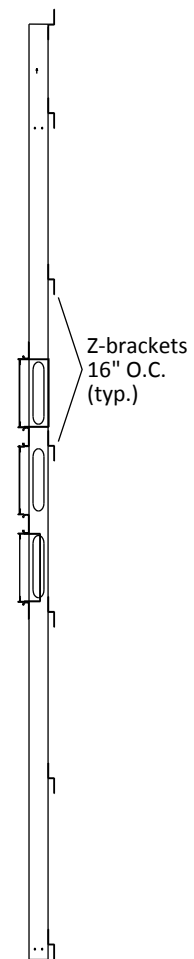

Figure 6.



MEDICAL GAS CONNECTIONS

Medical gas outlets are pre-manifolded and terminated near the top of Sections 1 and 3, or as indicated on the approved drawings.

1. Use extreme care in making medical gas service connections.
2. Each single-point connection has been provided with a color-coded medical gas label.
3. All medical gas connections are to be made and tested in accord with NFPA 99.

ELECTRICAL CONNECTIONS

1. Ensure all electrical power circuits are locked off prior to connection.
2. Review wiring diagram or shop drawings.
3. All connections are labeled at the point of connection.
4. Make electrical interconnections between framed sections. Typically these connections will run from the top of the upper tier in the center section (Section 2) across the front of the studs to the top of the upper tier in the adjacent sections (Sections 1 and 3). Ensure that the EMT conduit connector (or the flex connector if flex is used) is securely fastened to the top of the upper-tier chassis on both ends.
5. Connect electrical service according to wiring diagram, being careful to observe labeling at service connection.

LOW-VOLTAGE CONNECTIONS

1. Install each low-voltage device in accordance with manufacturer's installation instructions.
2. Test equipment in accordance with state or local codes.

DRYWALL INSTALLATION

1. Prior to installing drywall, ensure that all medical gas piping and electrical connections have been made and tested.
2. Cut the drywall to a size that will allow the material to fit over the Silhouette top and bottom flanges (Figure 7).
3. Cover the Silhouette unit with a plastic sheet or drop cloth while taping, texturing and painting (any additional wall covering may also be installed at this time).

IMPORTANT: Wainscoting should not be installed under the aluminum flanges of the Silhouette unit. Ideally, partial wall coverings should be installed after the painted finish trim is attached to the unit. If the coverings are to be installed before finish trim attachment, terminate 0.25" from the outer edge of the non-painted aluminum flange.

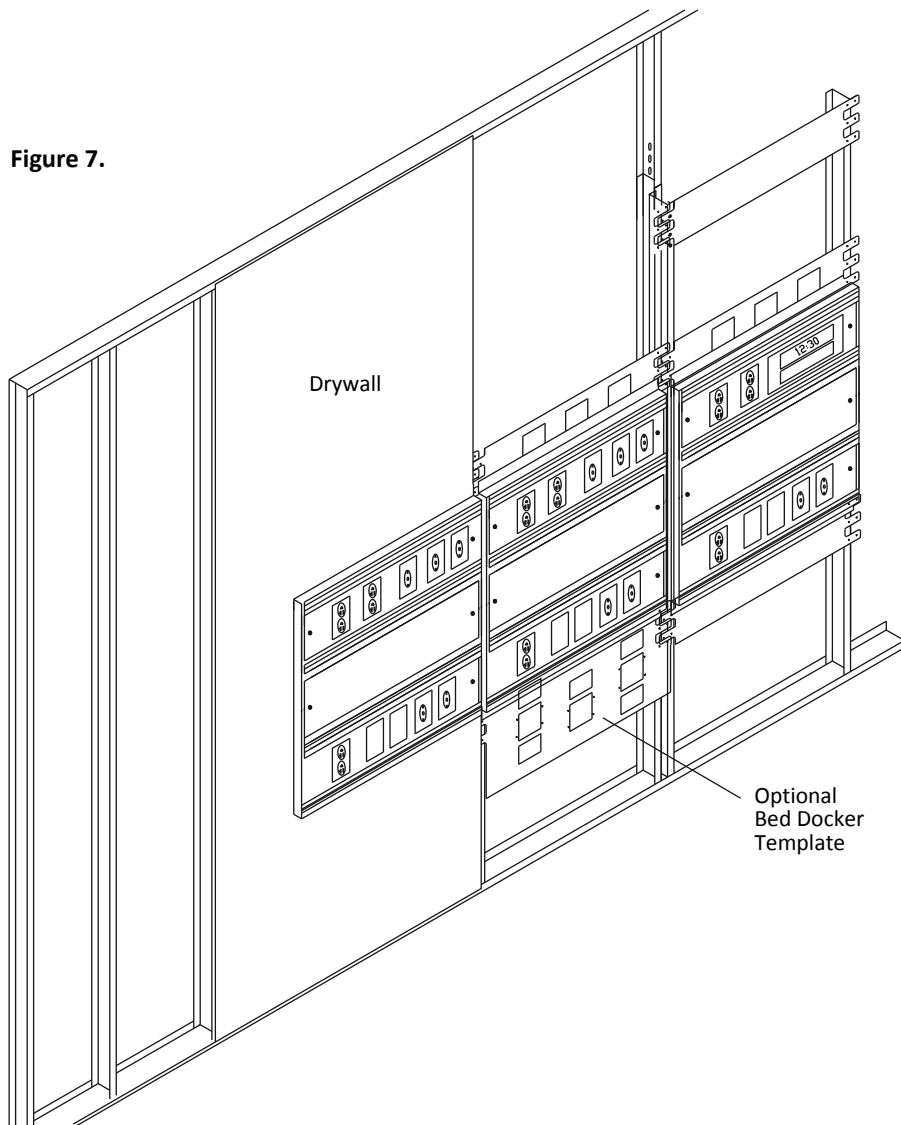

HORIZONTAL EQUIPMENT CHANNEL INSTALLATION

1. Place the top horizontal equipment channel into extrusion.
2. Ensure the equipment channel and extrusion interlock.
3. Secure the equipment channel in place using #12 sheet metal screws. Holes are pre-drilled.
4. Repeat the process for the remaining equipment channels. (Make sure channels are centered and flush with each other.)
5. **Make sure channels are installed right side up.** See Figure 8.

TRIM INSTALLATION

1. Attach the end caps to the unit with the #6 x 1" screws provided (Figure 9).
2. Press the vinyl trim strips into the grooves of the equipment channels (Figure 10).

CARE AND MAINTENANCE

1. Clean with mild detergent and warm water.
2. Avoid build-up of excessive moisture, as it can damage mechanisms in the unit.
3. Disinfect as required with disinfectant approved by the Environmental Protection Agency.
4. To remove difficult spots or stains, use standard household cleansers and a soft-bristled brush.
5. For parts or repairs, contact your sales representative. **NOTE: Do not use lubricants or oils on unit.**

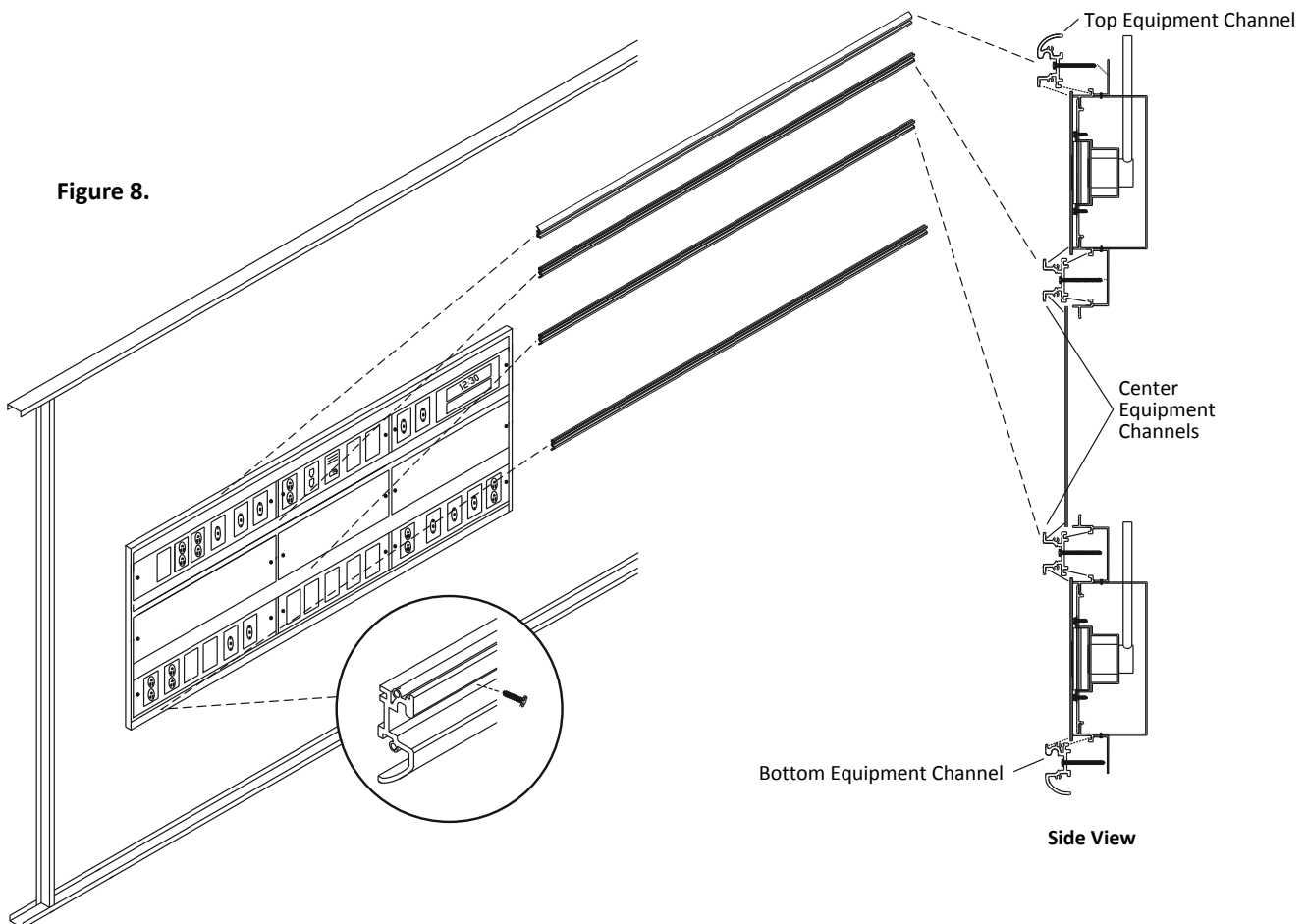

Figure 9.

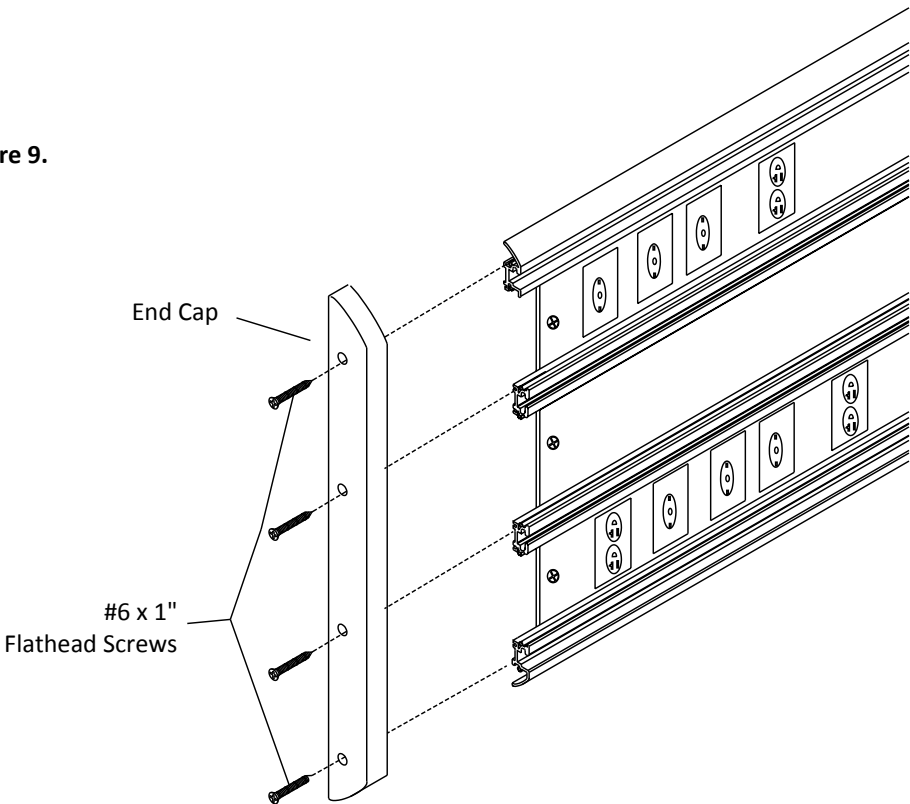
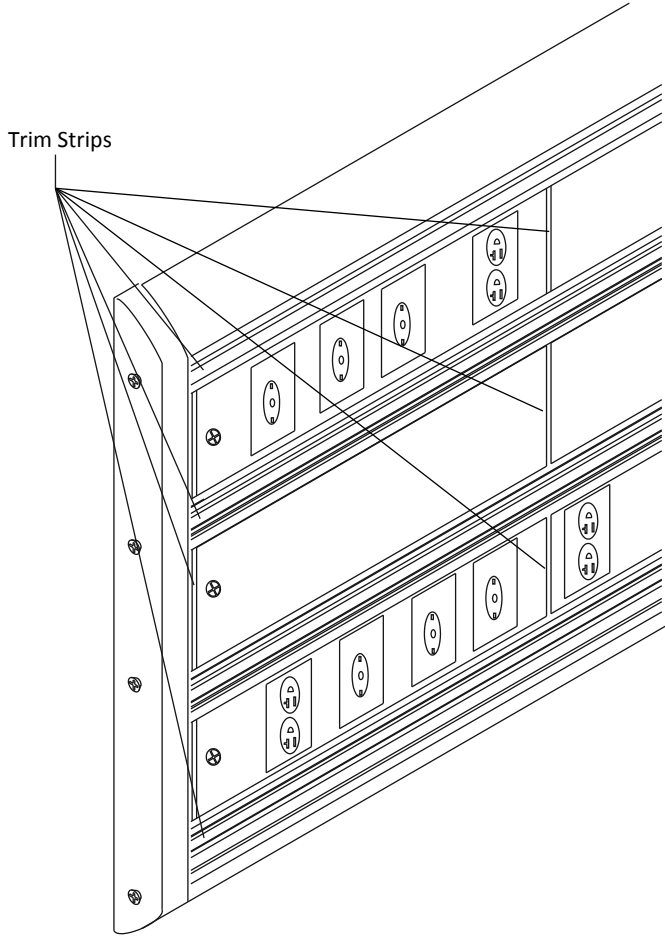

Figure 10.



INSTALLATION TERMS AND CONDITIONS

Each Modular Services unit, or unit section, shall be completely pre-wired for normal, emergency and low voltage according to the approved submittal. Communication devices and wiring shall be supplied by others. These devices include nurse call, television, code blue, telephone, monitor jacks, etc.

The customer shall be responsible for all electrical conduits, wiring hook-up of electrical services, and if applicable, interconnect wiring between sections. All hardware light fixtures shall be installed, wired and lamped by contractor. After installation is complete, the customer shall test equipment functions, as well as electrical receptacles and ground, in accordance with the National Electrical Code.

Medical gas contractor shall be responsible for piping and hook-up of all medical gas services. The medical gas contractor shall be responsible for purging, pressure testing, gas identification, and system certification in accordance with NFPA 99.

Modular Services Company shall have no responsibility or liability for delays, however caused. Owner shall hold Modular Services harmless from damages or injury related to any failure or neglect of owner, its employees, agents or licensees. Modular Services shall not be liable for consequential damages; makes no warranties, expressed or implied; and assumes no obligation other than those expressly contained herein.

WARRANTY

Modular Services Company warrants that all equipment assemblies shall be free from defects in material and workmanship for a period of 12 months from date of the owner's acceptance to the installing contractor or the date the equipment is put into service, whichever comes first. Warranty excludes electric lamps and/or any material not furnished by Modular Services. Warranty does not cover damage due to improper installation and/or abuse.

It is the responsibility of the customer to report any noted product deficiencies to Modular Services immediately upon discovery. It is the responsibility of Modular Services to expediently resolve the discrepancy. Any modification made to the product without the written authorization from Modular Services will void this warranty.

Also, in the event product modifications or repairs are made without the written consent of Modular Services, Modular Services shall not be held liable for any cost associated with the modification or repair.

There are no warranties of fitness which extend beyond the description on the face hereof.



109 NE 38th St. • Oklahoma City, OK 73105
Tel: 800.687.0938 • Fax: 405.528.0368
www.headwalls.com • info@headwalls.com